

Maststapler

MSI 20 T/25 T ■ MSI 30 T/35 T *Evolution*

- Standardhubhöhe : 3.30 m
- Tragkraft : 2000/2500/3000/3500 kg
- Perkins Turbo Dieselmotor : 60 PS (44.7 kw)
- Hydrostatische Kraftübertragung



** Präsentiert mit Optionen.

MSI 20/25/30/35 T



Tragkraft

bei 500 mm LSpA

MSI 20 T	2000 kg
MSI 25 T	2500 kg
MSI 30 T	3000 kg
MSI 35 T	3500 kg



Standardhubhöhe

3,30 m



Bereifung

Vorne.....275/70 R 22,5
Hinten.....7.00 x 12



Gabelzinken (mm)

Länge.....1100
Breite x Dicke.....100 x 45
Maximaler Abstand an der Außenkante.....1260



Hydraulische Bremsanlage Negativ Bremse



Perkins Turbo Dieselmotor

Typ.....404 C 22T
Hubraum.....4 Zylinder 2216 cm³
Leistung (ISO TR 14396).....60 PS/44.7 kw
Maximales Drehmoment.....190 Nm at 1800 rpm
Direkteinspritzung
Wasserkühlung



Hydrostatische Kraftübertragung REXROTH

Antriebsräder.....2
Elektrohydraulischer Fahrtichtungsschalter
Geschwindigkeit vorwärts/rückwärts.....1/1
Maximale Fahrgeschwindigkeit.....20 km/h



Hydraulik

Zahnradpumpe.....125 bars/73 l/mn



Füllmengen

Kühlsystem.....9 l.
Motoröl.....6,2 l.
Hydrauliköl.....95 l.
Kraftstoff.....73,5 l.



Eigengewicht (mit Gabeln)

MSI 20/25/30/35T.....3840/4150/4530/4980 kg
Gesamtbreite.....1,32 m
Gesamthöhe.....2,30 m
Gesamtlänge.....4,04/4,04/4,08/4,13 m
Bodenfreiheit.....215 mm

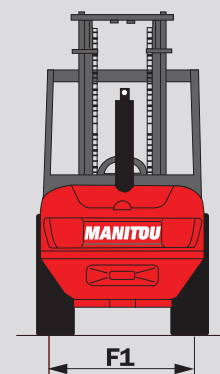
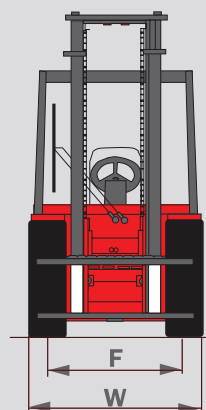
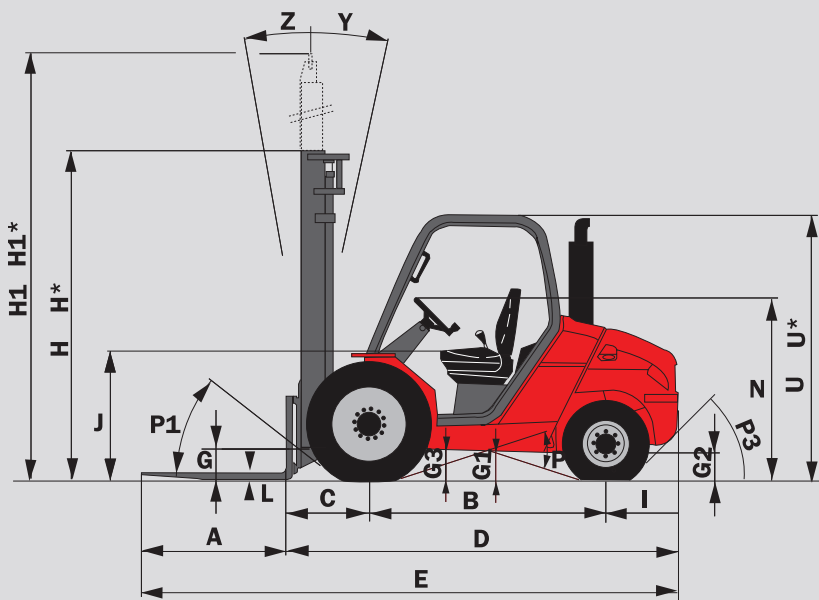

	MSI 20 T +BUGGIE	MSI 25 T +BUGGIE	MSI 30 T +BUGGIE	MSI 35 T +BUGGIE
A	1100	1100	1100	1100
B	1800	1800	1800	1800
C	625	625	630	630
D	2945	2945	2980	3030
E	4045	4045	4080	4130
F	1046	1046	1046	1046
F1	1102	1102	1102	1102
G	270	270	270	270
G*	240	240	240	240
G1	260	260	260	260
G1*	260	260	260	260
G2	215	215	215	215
G2*	230	230	230	230
G3	270	270	270	270
H	2300	2300	2300	2300
H*	1950	1950	2050	2050
H1	4131	4131	4193	4193
H1*	4470	4470	4500	4500
I	520	520	550	600
J	1025	1025	1025	1025
K	1260	1260	1260	1260
L	40	40	45	45
N	1450	1450	1450	1450
O	100	100	100	125
P1	49,5°	49,5°	49,5°	49,5°
P2	40,5°	40,5°	40,5°	49,5°
P3	44°	44°	40°	40°
R	2310	2310	2310	2330
S	2545	2545	2580	2590
T	4525	4525	4560	4595
U	2105	2105	2105	2105
U*	1990	1990	1990	1990
V	2600	2600	2635	2665
V1	150	150	150	100
W	1323	1323	1323	1323
Y	12°	12°	12°	12°
Z	10°	10°	10°	10°

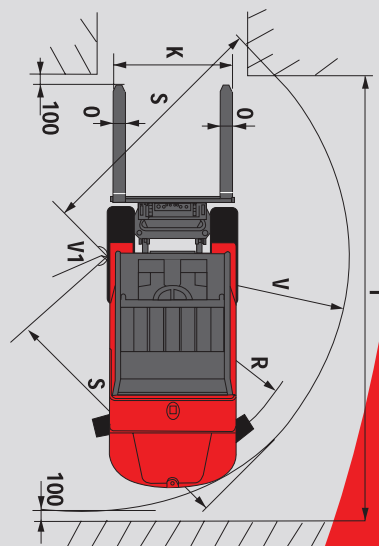

Änderungen im Sinne des technischen Fortschritts vorbehalten.
Die in der Vorliegenden Broschüre vorgestellten MANITOU - Maschinen können mit Zusatzgeräten
ausgestattet sein.

H - H1 - R = Standard
H*-(Triplex 3,70 m) H1* = Option

U* = MSI 20/25 BUGGIE
G* - G1* - G2* = mit Last



Deutschland und Österreich : **MANITOU Deutschland GmbH**
61239 OBER-MÖRLEN ☎ 06002 - 9199 - 0
Andere Länder : **MANITOU B.F. S.A.**
44158 ANCENIS cedex - FRANKREICH ☎ 33 2 40 09 10 11
www.manitou.com
700314DE

